

IoT-BASED SOIL CONTENT ANALYSIS

Vidhya P¹, Ninshiya Mary J², Yamuna Mary J³, Suriya Ponselvi R⁴, Mr.K.Subramanian⁵

¹Scholar, Electronics and Communication Engineering National Engineering College, Kovilpatti. 1911111@nec.edu.in

²Scholar, Electronics and Communication Engineering National Engineering College, Kovilpatti. 1911092@nec.edu.in

³Scholar, Electronics and Communication Engineering National Engineering College, Kovilpatti. 1911115@nec.edu.in

⁴Scholar, Electronics and Communication Engineering National Engineering College, Kovilpatti. 1911107@nec.edu.in

⁵Electronics and Communication Engineering, National Engineering College, Kovilpatti

DOI: 10.47750/pnr.2023.14.04.16

Abstract

Agriculture is the primary economic driver in every developed nation. Agriculture that uses smart technology encourages agricultural innovation, which helps solve economic problems. Smartphones and other Internet of Things devices make this possible. Farmers are able to monitor both their data and their activities. The Internet of Things is connected by embedded devices such as sensors, actuators, and others. The increased reliability of farmers will result from rapidly implementing Internet of Things technology in agriculture. The greater output of crops is required to feed a growing population. The optimal conditions for crop yields are moisture, temperature, and pH. The nutrients and moisture in the soil are essential for crop growth. It is imperative that crop production food levels be monitored more frequently. For this, a nutritional analysis is required. Take frequent readings of the soil's temperature, pH, and moisture content. Temperature, soil moisture, and microcontrollers control soil content, pH, and moisture. These findings are then periodically updated by cloud servers. Electrochemical sensors measure soil nutrients. The elements phosphorus, potassium, and nitrogen. Analysis and recommendations regarding the nutrients in live soil. This article provides information and recommendations regarding the pH of soil. Field maintenance and fertilization considering soil constituents. IOT esp8266 provides farmers with information.

Keywords: IoT; Soil; Moisture; Temperature.

I. INTRODUCTION

Agriculture is an essential composition of existence, and the Internet of Things provides a superior infrastructure for efficient and effective farming. The Internet of Things (IoT) solutions are growing in the agricultural sector. According to current projections, the number of connected agricultural devices will reach 75 million by 2020, representing an average annual growth rate of 20%. In the meantime, it is anticipated that the global market for intelligent jobs will triplicate to reach \$15.3 billion by 2025[1].

To get the best possible results from the crops, it is essential to conduct a thorough soil test to determine the type of fertilizer to apply based on the nutrients already present in the soil. Testing the soil allows for creating[20] a comprehensive plan for nutrient management. Nitrogen (N), phosphorus (P), and potassium (K) are the three primary nutrients that are found in soil[3]. We can determine the fertility of the soil by analyzing the correlation between the ground's pH and the number of various macronutrients present[3]. Agriculture is the primary means people in India support themselves and their families daily. Indian farmers who are economically disadvantaged face challenges in accessing and utilizing technology due to limited support, which may be attributed to the perception that their occupation is less complex[4].

This is because the age of technology has made acquiring technology easier. Through the completion of this project, a monitoring and management system that can be utilized to enhance greenhouses will be created. The Arduino microcontroller serves as the primary-entire system's command and processing component of the following are some of the functions that are carried out by the system:

1. It provides water in proportion to the moisture already present in the soil.
2. Regularly scheduled automatic data updates to protect plants from being scorched by the surrounding air temperature.

3. Soil pH automatic detection system.

4. To prevent water from running off across the field, use a soil sensor to monitor the amount of excess moisture.

The agricultural industry plays a substantial role in a country's overall economic advancement and progress. The exponential growth of the world's population underscores the importance of food and plant production[4]. As a result, there have been a lot of noticeable shifts in this region. Producing and storing agricultural goods can be done in a variety of ways. The Internet of Things, various forms of technology, artificial intelligence, and various other forms of technology are utilized in smart agriculture[5]. The application of this technology may, in some circumstances, call for specialized knowledge and may incur additional expenses[6]. An essential component of agriculture is the practice of precision farming, which places a premium on the technology that facilitates the transfer of information[7]. The levels of nutrients in the soil can be evaluated either in a laboratory setting or through the use of a soil meter[8]. It is possible to collect data in real time using various sensors. For a field to produce better results, we need to identify crops suited to it. The amount of land available, the climate, the amount of water that is available, the temperature of the soil[9], the amount of sunlight, the amount of wind, and the level of pollution are all factors that can affect crop yield and production. Therefore, with the help of sensors, information regarding the phosphorus (P), nitrogen (N), and potassium (K) content of the soil, as well as pH, temperature, humidity, water level, and various forms of water pollution, will be gathered[10]. With this information, the crops that are most suited to their requirements can be recommended. However, we will require a significant financial investment, specialized knowledge, and ongoing maintenance to manage these sensors effectively.

II. PROPOSED SYSTEM

The provision of sustenance is a fundamental requirement for the survival of the human species. The production of food crops is a significant concern due to the expanding population and escalating climatic changes. Water scarcity is a significant limitation.

Therefore, the utilization of fertilizers is employed to enhance crop yield. However, as a result, a greater quantity of water is utilized. In order to mitigate this phenomenon, it is imperative to identify and track the soil parameters through the process of monitoring, which involves:

- ✓ The pH level of the soil was measured utilizing a pH sensor.
- ✓ The measurement of the soil moisture system utilizes a soil moisture sensor. The determination of soil temperature level is accomplished through the utilization of DH11.
- ✓ The data is gathered from diverse locations using a variety of sensors and is monitored on a daily basis. The project aims to integrate a Wi-Fi module and a microcontroller through the Internet. The scope of implementation is constrained to the Wi-Fi module due to the author's proficiency limitations in lower-level programming languages such as C/C++. This implementation serves as a demonstration of how Arduino can be utilized for implementation purposes, as well as to compare sensor data output.

The implementation of a system for monitoring in real-time has the potential to facilitate the monitoring and regulation of the mining environment. The Node MCU technology presents a multitude of benefits that are well-suited for employment in real-time monitoring systems. The main aim of this project is to develop a real-time monitoring system that is effective in identifying various leaked mine gases promptly. This will enable the implementation of appropriate preventive measures. The proposed study aims to conduct research investigations with the specified objectives:

- ✓ The identification of varying pH levels in a given environment.
- ✓ The establishment of communication between sensors and a Wi-Fi module.
- ✓ The establishment of a wireless sensor network.
- ✓ The present study concerns the development of a system for monitoring in real time.

III. METHODOLOGY

3.1 BLOCK DIAGRAM

Upon completion of the project, a schematic representation of the composition of the soil is identified through the employment of a pH sensor, and the ascertained data is subsequently transmitted to the microcontroller. The microcontroller is utilized to display the value on the screen, while the transmission of data to the cloud page is facilitated by esp8266.

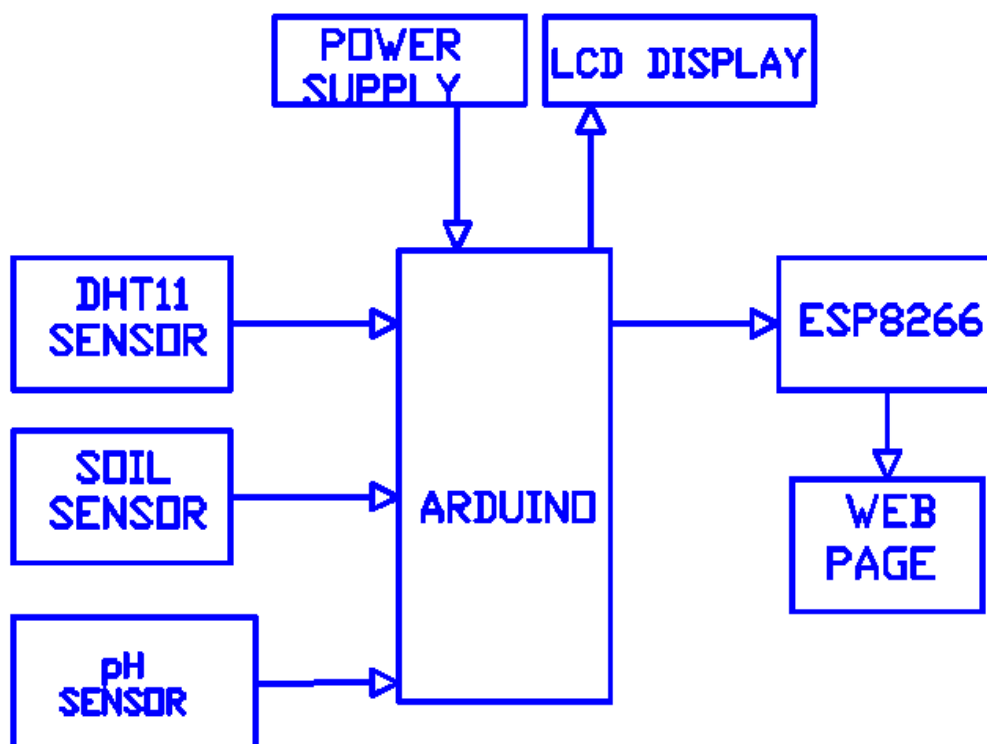

3.2 METHODOLOGY

Methodology parts conducted for this thesis were including:

- Observation and analysis of the problem identification of the excess of agri field monitoring s process system.
- Analysis of the existing methodology.
- To improve existing methods.
- Methods to tackle the disadvantages of the current methods.

Design a new circuit and execute the new proposed system.

- An Arduino, Wi-Fi module 8266, Temperature sensor, Soil sensor, pH Sensor, and monitor (LCD) Screen were used to create the model.
- Five layers were used to classify the device overview protocol. The first layer consists of environmental parameters obtained by the survey.
- The analysis of the sensor's characteristics and features represents the second layer. The third layer included the decision-making, sensing, measuring, threshold valve fixing, sensitivity periodicity, timing, and space.
- The fourth layer of the system involved the acquisition of sensor data.
- The system that was suggested constituted the fifth layer. Upon activation by the microcontroller, the sensor procured the requisite data and subsequently transmitted it to the users through the Wi-Fi module for analytical purposes.
- The cloud page is created by www.thingspeak.com, which supports free domain hosting.

- The Main page of the webpage allows the user to enter the destination of the sensor's updated values from the embedded system by using Wi-Fi technology.
- sensor values are continuously uploaded to the cloud for analysis and further use.

3.3 HARDWARE USED

1. ESP8266 Wi-Fi module
2. Power supply
3. Arduino
4. pH Sensor
5. Temperature sensor
6. Soil sensor

3.3.1 ESP8266 wifi module

The platform as mentioned above provides a low-cost, freely available answer for the IoT. The device's primary components are the ESP-12 hardware-based module and the firmware that runs on Espressif Systems' ESP8266 Wi-Fi System-on-Chip. Later, ESP32's 32-bit microcontroller unit support was added. The firmware for the Node MCU is unique in that it is both freely available and designed. Node MCU is an initialism for "node" and "microcontroller unit" (MCU), respectively. The term "Node MCU" refers only to the software and does not cover the hardware used in its development. Both the firmware and the design code can be found in the public domain. The firmware is written in Lua scripting language. This project's firmware was adapted from the eLua initiative, and the ESP8266 platform's Non-OS SDK was built with the help of the Express framework. The system makes use of a wide range of open-source components, such as lua-Json and SPIFFS. Due to constraints, users will need to develop enterprise-specific firmware and selectively implement only the modules that are useful to their organization. There is also ESP32 support, which utilizes a 32-bit architecture. To connect the USB controller to a small board containing the MCU and antenna, the best-integrated circuit uses a dual in-line package (DIP). The use of the DIP format makes for simple breadboard prototyping. The original concept was built on the ESP12 module, also used in the ESP8266. The Tensilica Xtensa LX106 core Wi-Fi System-on-Chip (SoC) is featured in this module. It is widely used in numerous IoT applications.



Figure 3.3.1 ESP 8266 Wi-Fi module

3.3.2 POWER SUPPLY ADAPTOR

To put it another way, a 12-volt adapter is an electrical converter in the shape of a plug. This component is referred to by a number of different names, some of which are plug light, plugin adapter, adapter block, home power, line power, wall adapter, power outlet, and power adapter. According to the information presented in the section on battery charging mechanisms, adapters for battery-powered devices can either be chargers or power adapters. AC adapters

are what are used to provide power to electronic devices that do not have their own built-in voltage and power source. All electronic components, whether they are internal or external, have the same architectural foundation. The 120VAC input from a wall outlet is converted into 12VDC by a 12VDC wall plug adapter. Adapters allow for portable setups to function normally, even in the absence of complex connections. Control of RGB (W)/DMX, dimmers, and low-voltage in-line devices are all supported by the adapters. When it comes to low-voltage LED lighting adapters, consumers can choose from a plethora of different models and voltage/wat

Manufacturersources, manufacturers may have a gr when they use external power sourcesearer sense of safety. Even though many of these devices are powered by electricity, which poses the risk of electric shock, the amount of power that they consume is typically relatively low. The device lowers the risks associated with the entry point when an external source like a coaxial cable powers it.

- Heat reduction - Heat and direct sunlight can shorten the lifespan of electronic devices and cause malfunctions or failures by causing damage to or revealing the internal components of the device. Heat can also cause components to become exposed. The heat is removed from the device by the circuit.
- Electrical noise reduction - .A "clean" DC filter on the external adapter makes it possible to insulate noise-sensitive circuits from the potentially noisy AC power line or the power supplied by the vehicle. The square of the distance is a factor that determines how much electric noise is dampened.
- Heat reduction - Heat reduces the reliability and life of electronic components and can cause electronics to malfunction or malfunction. A separate circuit removes heat from the device.
- Reduced weight and size - Remove the power pack and main connector from the rechargeable battery pack to reduce the weight and size to be moved.
- Flexibility - Electronic components are more prone to failure than other circuits because they are subject to electrical spikes and generate internal waste. Users can quickly replace the external power supply without repairing the power supply.



Figure 3.3.2 Power Supply Adaptor

3.3.3 ARDUINO UNO

Arduino is a user community, project, and open-source hardware and software company that designs and manufactures a microcontroller board as well as other microcontroller components. These are used in the construction of digital devices. Anyone is able to create Arduino boards and distribute software because its products are licensed under the GNU Lesser General Public Licence (LGPL) or the GNU General Public Licence (GPL).

Most boards have a linear regulator that outputs 5 V and either a crystal oscillator or a ceramic resonator that operates at 16 MHz.

Because of these limitations, certain designs, such as the LilyPad, can function at 8 MHz and do not need to have a controller built right into them. The pre-installed bootloader on an Arduino microcontroller makes it simple to transfer programs from a computer to the on-chip flash memory. optiboot is set as the default bootloader for Arduino UNO

boards. The code for the program is transferred into the clipboard from another computer through a serial connection. Some serial Arduino boards have phase shifters built into them, which allow them to convert between the logic levels of an RS-232 connection and the signal levels of a transistor-transistor logic (TTL) connection. Currently, Arduino boards are programmed by connecting them to a computer via the Universal Serial Bus (USB) and employing a USB to serial adapter chip like the FTDI FT232. On some boards, such as the more recent iterations of the Uno board, the FTDI chip has been replaced with a separate AVR containing USB-to-serial firmware and reprogrammable through its very own ICSP header. Other options, such as the Arduino Mini and the unofficial Boarduino, use Bluetooth, USB to serial adapter cards or cables, or a combination of these and other technologies. Instead of the Arduino IDE, you should use a traditional microcontroller tool and program the Arduino with the standard AVR InSystem Programming (ISP) language—the official Arduino Uno R2 with a description of the I/O locations. The ATmega328 (datasheet) is the core of the Arduino Uno, a microcontroller board. It has a USB connection, power input, ICSP header, reset button, and 14 input/output pins, six of which can be used as PWM outputs. It also has a 16 MHz ceramic resonator, six analog inputs, and six pins that can be used as PWM outputs. It contains everything required to support a microcontroller; all left to do is connect it to your computer using a USB cable or provide power to it using an AC-DC adapter or battery, and you are good to go. The USB-to-serial driver chip manufactured by FTDI is absent from TheUno, marking a significant departure from all other boards before it.

Most boards have a linear regulator that outputs 5 V and either a crystal oscillator or a ceramic resonator that operates at 16 MHz.

Because of these limitations, certain designs, such as the LilyPad, can function at 8 MHz and do not need to have a controller built right into them. The pre-installed bootloader on an Arduino microcontroller makes it simple to transfer programs from a computer to the on-chip flash memory. optiboot is set as the default bootloader for Arduino UNO boards. The code for the program is transferred into the clipboard from another computer through a serial connection. Some serial Arduino boards have phase shifters built into them, which allow them to convert between the logic levels of an RS-232 connection and the signal levels of a transistor-transistor logic (TTL) connection. Currently, Arduino boards are programmed by connecting them to a computer via the Universal Serial Bus (USB) and employing a USB to serial adapter chip like the FTDI FT232. On some boards, such as the more recent iterations of the Uno board, the FTDI chip has been replaced with a separate AVR containing USB-to-serial firmware and reprogrammable through its very own ICSP header. Other options, such as the Arduino Mini and the unofficial Boarduino, use Bluetooth, USB to serial adapter cards or cables, or a combination of these and other technologies. Instead of the Arduino IDE, you should use a traditional microcontroller tool and program the Arduino with the standard AVR InSystem Programming (ISP) language—the official Arduino Uno R2 with a description of the I/O locations. The ATmega328 (datasheet) is the core of the Arduino Uno, a microcontroller board. It has a USB connection, power input, ICSP header, reset button, and 14 input/output pins, six of which can be used as PWM outputs. It also has a 16 MHz ceramic resonator, six analog inputs, and six pins that can be used as PWM outputs. It contains everything required to support a microcontroller; all left to do is connect it to your computer using a USB cable or provide power to it using an AC-DC adapter or battery, and you are good to go.

The USB-to-serial driver chip manufactured by FTDI is absent from TheUno, marking a significant departure from all other boards before it. Instead, it utilizes a USB-to-serial converter that is programmed on an Atmega16U2 (or an Atmega8U2 if you have the R2 upgrade). It is very simple to enter DFU mode thanks to the resistor that is located on the Fix 2 component of the Uno board. This resistor pulls the 8U2 HWB line to ground. The following new capabilities have been added to this board in Update 3:

- Pin Assignment: SDA and SCL pins have been placed next to the AREF pin, and two new pins have been placed next to the RESET pin on the IOREF board. This change enables shields to be used in place of electrical equipment. In the not-too-distant future, the shield will be compatible with circuit boards that use AVRs running at 5V and Arduino Dues running at 3.3V.

The second one is a dangling pin that has been set aside for some undetermined purpose.

- Powerful reset circuit.
- Atmega 16U2 in place of the 8U2 version.

"Uno" is an Italian word that translates to "one," and it was chosen as the name of the upcoming version of Arduino 1.0.

From this point forward, Uno and version 1.0 will serve as the reference version for Arduino. The Arduino Uno board is the most recent in a line of USB Arduino boards and modules that are compatible with the Arduino platform.



Figure 3.3.3 Arduino uno

3.3.4 PH SENSOR



The predominant method for measuring pH is using an electrochemical pH sensor. The integrated pH sensor comprises two distinct components: the measuring electrode and the reference electrode. This type of sensor operates on electrochemistry principles to determine a solution's pH. The measuring electrode is tasked with detecting alterations in pH levels, whereas the reference electrode sustains a signal that can be juxtaposed. A pH meter, which has a high impedance, is employed to exhibit millivolt signals in pH. The utilization of integrated pH sensor technology has the potential to be implemented in the manufacturing of diverse commodities, including but not limited to industrial or process pH sensors and laboratory pH sensors. The pH measuring circuit comprises three components: the measuring electrode, the reference electrode, and the pH sensor. The pH sensor comprises a temperature sensor, preamplifier, and analyzer or transmitter. The pH measurement circuit comprises a battery as its primary component. The voltage for measurement is obtained from the positive terminal, while the voltage applied is obtained from the negative terminal. The quantification of an electrode's responsiveness to hydrogen ions leads to the generation of an electrical potential (voltage) that exhibits a linear correlation with the concentration of hydrogen ions in the solution. The electrode material maintains a constant potential that is measurable by the test electrode.

Figure 3.3.4 pH sensor

3.3.5 Temperature -DHT11- Sensor

The DHT11 sensor is a versatile IC detecting heat and moisture. It can simultaneously transmit and receive signals. Utilizing temperature and humidity monitoring technology and specialized digital module detection technology guarantees the product's longevity and reliability. A high-performance 8-bit microcontroller is linked to an NTC temperature sensor and a humidity-sensing component. These two sensors are integrated into the system. This article describes several devices and resources that can assess and modify a space's humidity levels. The HVAC system,

dehumidifiers, testing and inspection tools, automation tools, automobiles, data loggers, weather stations, humidity regulators, and purification systems are all examples. What makes a sensor useful is discussed in this article. The sensor's relative humidity and temperature-measuring abilities, low cost, long service life, high sensitivity, quick response time, resistance to interference, long-range signal transmission, signal output, and accurate calibration are just a few of these features.



Figure 3.3.5 Temperature sensor

3.3.6. Moisture Sensor

The employment of the Soil Moisture Sensor enables the achievement of this objective. If the humidity reading obtained from the sensor falls below the designated threshold, the digital output will register at a high level of 5 volts. Conversely, the digital output will register low if the reading surpasses the threshold. In order to assess the soil moisture content, a digital pin is utilized to obtain a direct measurement of the soil. The adjustment of voltage necessitates the utilization of a potentiometer. The YL69 Soil Moisture Sensors are utilized with an LM393 Comparison module to assess and appraise diverse soil types. The YL69 sensor is comprised of a dual-electrode configuration. The device can detect and interpret the prevailing levels of humidity. The measurement of soil moisture content is obtained by assessing the resistance to the flow of electric current through the soil between the electrodes. An increased presence of water in the soil results in a reduction in electrical resistance to current flow. However, the sensor module exhibits a significant level of functionality even in environments characterized by low levels of humidity.

The sensor exhibits the ability to produce both digital and analog signals. While digital output offers greater convenience, it lacks the same degree of precision as its analog counterpart. The Atmega 328P-PU microcontroller for Arduino Uno is equipped with an integrated 10-bit 6-channel Analog-to-digital (A/D) converter. This feature enables the analog input pins on the Arduino to decode the analog signal transmitted by the sensor and generate a binary integer within the range of 0 to 1023. Increased productivity has the potential to decrease wetness. Optimization of O/P will be achieved as a direct result of this. The presence of moisture in the ground can initiate the generation of an electrical current that will traverse from an initial point to a terminal point. This statement indicates that the subject exhibits traits that are similar to those of a system that is closed. Assuming the current circumstances, the output will be equivalent to zero within this particular scenario. The farmer is expected to receive a justifiable remuneration for his efforts owing to the elevated index. The sensors in this area are coated with platinum plating, which serves the dual purpose of safeguarding them against corrosion and enhancing their effectiveness and durability.

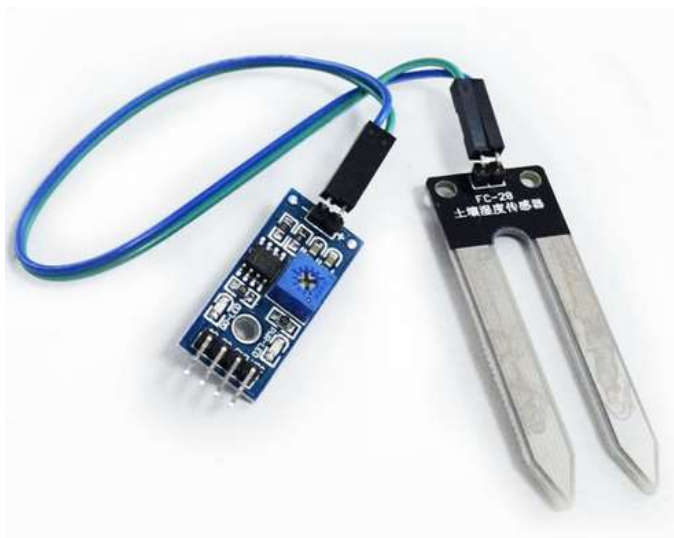
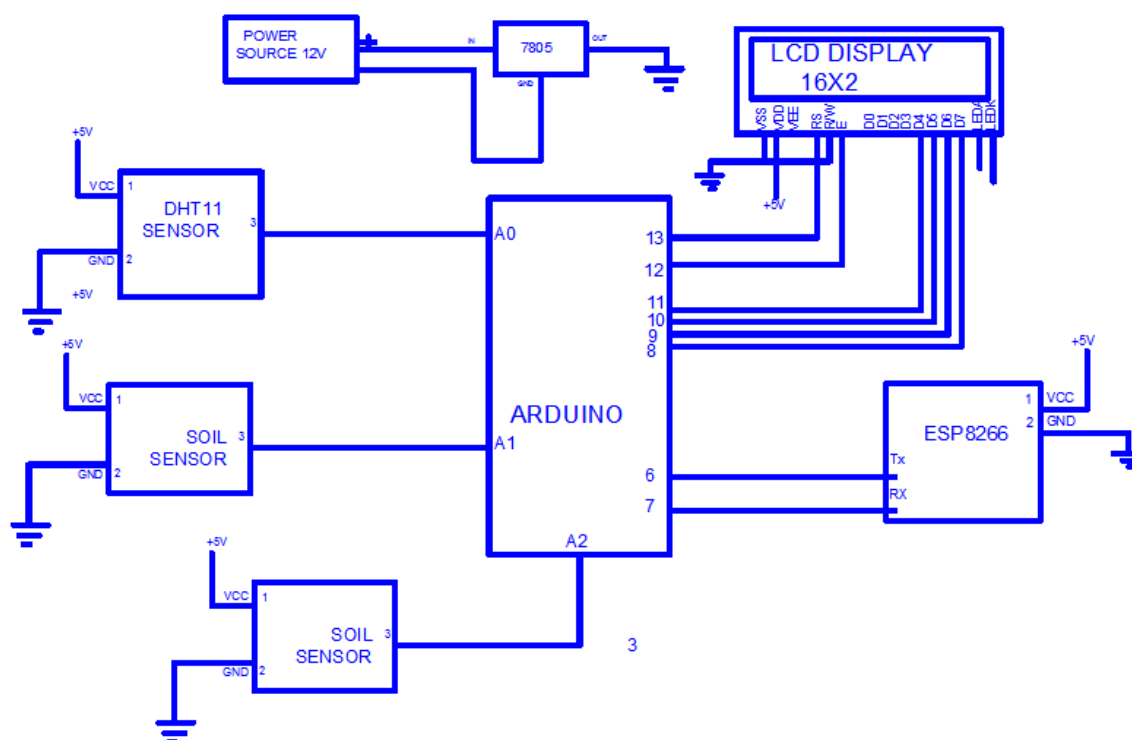

Figure 3.3.6 Moisture sensor

3.3.7 CIRCUIT DIAGRAM



3.4 SOFTWARE REQUIREMENTS

3.4.1 ARDUINO COMPILER

After a brief initialization phase, the Arduino environment takes the user's sketch and converts it into a C++ program. The next step is to deduce the connections between the sketch and other elements. A compiler, in this case, `avr-gcc`, takes the human-readable code and converts it into machine-readable instructions. These scripts of code are known as "object files." This is done after the code has been transmitted. Although Python could be used to program some Arduinos, we do not advise doing so. GitHub hosts the Python Arduino Prototyping API v2 project.

For basic tasks, this tool is adequate. Two versions of Arduino are available for download: the stable release (Arduino 1.0.x) and the beta release (Arduino 1.5.x). Both of these variants are available. Each of the 00xx versions of Arduino is available for download. Multiple platforms, including Mac OS X, Windows, and both 32-bit and 64-bit distributions of Linux, are compatible with the Arduino IDE. Arduino is largely a library of C and C++ functions that can be called from your code, as has been said. Simple edits are applied to the sketch before it is sent directly to a C/C++ compiler. This includes the automatic creation of function prototypes. The programming language known as Arduino is based on C++, and it incorporates many OOP concepts. C++'s object-oriented programming (OOP) capabilities allow for encapsulating a blinking LED's state variables and operational features within a single class. This is not a difficult job at all. The entire code has been documented.

IV RESULTS

4.1 SENSOR CALIBRATION

The accuracy of the pH sensor was evaluated by utilizing pH buffer solutions obtained from the laboratory. 16 pH buffer tablets were used to prepare a series of pH buffer solutions ranging from 3 to 10, with an increment of 1. The microcontroller monitored the voltage generated by the pH electrode upon immersion in each solution. The calibration curve obtained is depicted in Figure 7.1.

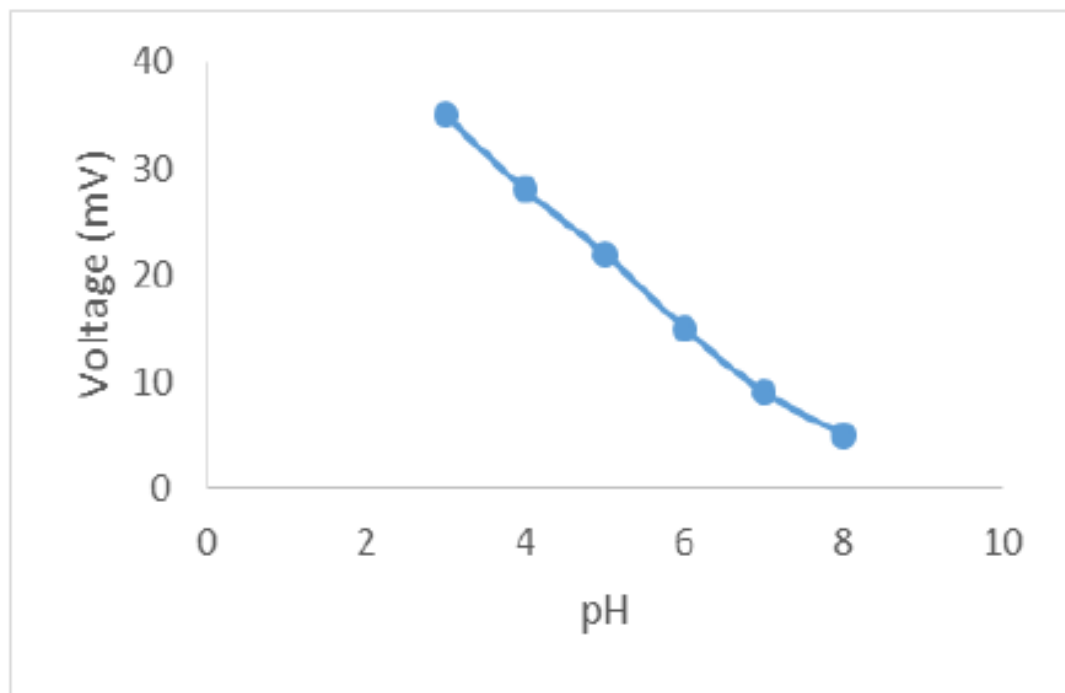

Figure 4.1 pH Calibration Curve

The voltage values have been quantized to make the system more user-friendly; the pH will drop by one point for every eight mV step in the negative direction. It is impossible to infer the soil's acidity or basicity based on pH values below three or above 8. As a result, we did not include any samples in the calibration set with excessively high or excessively low pH values.

The sensor is efficient because the resistance of the soil decreases as the moisture content of the soil increases. When there is more water in the soil, the soil's strength decreases. To determine how well the soil moisture sensor works, an experiment was conducted in which samples of soil representing all three possible moisture states (completely dry, intermediate, and wet) were used. The voltage measurements from moist soils ranged from 2.62 to 3.21 V, whereas the measurements from dry soils never exceeded 0.4 V. When the soil was only slightly damp, the reading on the voltmeter was linear with the moisture content of the soil. The trend as mentioned above was utilized

in the derivation of the calibration equation for this investigation, which can be seen in Equation (1). In this equation, the variable referred to as ADC_Value represents the analog voltage output by the ADC, and the Moisture Content variable refers to the amount of moisture contained within the sample as a percentage.

$$\text{Water Activity of the Air (ADC)} = (\text{ADC_Value}/3.3) * 100$$

ADC Value multiplied by 100 gives the Water Activity of the Air (ADC) value.

On the market today is a digital soil temperature sensor that is both extremely accurate and resistant to the elements. This sensor is known as the DS18B20. The temperature of the soil is encoded using a 12-bit system, making it possible to identify even the most minute of fluctuations quickly. For the purposes we were using it for, there was no need to fine-tune the calibration of the soil temperature sensor.

4.2 PROTOTYPE

It was demonstrated that the prototype was successful through testing in both open fields and flower pots. During the many iterations of testing, a wide range of factors was considered, leading to refinements. Figure 7.2 depicts a fully-operational model of the system that was constructed in a container. Through Wi-Fi, the sensors transmitted the data they collected to an online web page. This method was used to retrieve the data from the device after the cloud page was finished being processed.

A USB cable is being used to supply power to the microcontroller board shown in the image. Nevertheless, a DC supply and a power adapter were utilized throughout the testing that took place in a real-world environment. The firmware was designed with a standby mode that decreased the amount of power that was consumed by the device when it was not in use. During a series of tests conducted in the field, it was discovered that the pH sensor had an error of up to 1 when the voltage difference was four mV or higher. On the other hand, implementing a buffer circuit resulted in a significant decrease in this deviation. The development of pH sensors that do not require quantizing voltage and have step sizes as small as 0.1 remain open areas.



Figure 4.2 Working Prototype

The results of the field tests indicated that the current moisture level had a major impact on the moisture sensor's imprecision. Accidents are more likely to occur when the ground is even slightly damp. From a maximum value of 100% for soil moisture content, the margin of error decreases to zero as the level of soil moisture rises. In Figure 7.2, we see the validation curve used to evaluate soil moisture gauges' degrees of accuracy. Figure 7.2 depicts the linear voltage curve, which deviates noticeably from the 10--40% moisture range. After doing the maths for a group of 12, we determined that the standard deviation of the errors was only about 9.4 percent. This estimate, while not entirely accurate, is close enough to be used in determining the amount of water needed by the soil. Using exact moisture sensors would improve the data's accuracy, but it is not feasible because doing so would significantly increase the cost of the system. There is a tradeoff between the desired level of precision and the sensors' price. The investigation has found the optimal balance between achieving desirable results and pursuing a cost-cutting strategy.

4.3 CLOUD PAGE RESULTS

The IoT Based soil condition monitoring system's hardware implementation using Arduino and IOT is shown below.



Figure 4.3 Graphical Results by IOT

By this resulting this graph shows,

Field chart-1 shows the pH value presented in the soil in an agri field. This value is read by the pH sensor and updated every second by using esp8266. This graph shows the pH value present in the soil in pH by time period. The maximum value is 10, acquired on 1-April, and the minimum value is 0, acquired on 20-Nov.

Field chart-2 shows the temperature value presented in the soil in a filed area. This value is read by a temperature sensor and updated every second by using esp8266. This graph shows the temperature present in the agri field in Degree Centigrade by time period. The maximum value is 36°C, acquired on 1-Nov, and the minimum value is 27°C, acquired on 15-Nov.

Field chart-3 shows the dryness value presented in the mine area. This value is read by soil sensors and updated every second by using esp8266. This graph shows the water level present in the soil in percentage by time period. The maximum value is 90% acquired on 1-Nov, and the minimum is 10% acquired on 20-Nov. chart-4 shows the Humidity value presented in the soil in a field area. This value is read by a temperature sensor and updated every second by using esp8266. This graph shows the Humidity present in the agri field in percentage by time period. The maximum value is 70 acquired on 1-Nov, and the minimum value is 10 acquired on 15-Nov.

REFERENCES

1. Gauche, Heloísa, Fernando Ribeiro Oliveira, Claudia Merlini, Ana Paula Hiller, António Pedro G. V. Souto, Isabel Dias Cabral, and Fernanda Steffens. "Screen Printing of Cotton Fabric with Hydrochromic Paste: Evaluation of Color Uniformity, Reversibility and Fastness Properties." *Journal of Natural Fibers* 19, no. 7 (2022): 2694-2705.
2. Reimer, Marie, Tobias Edward Hartmann, Myles Oelofse, Jakob Magid, Else K. Bünemann, and Kurt Möller. "Reliance on biological nitrogen fixation depletes soil phosphorus and potassium reserves." *Nutrient Cycling in Agroecosystems* 118, no. 3 (2020): 273-291.
3. Wang, Yi, Yi-Fang Chen, and Wei-Hua Wu. "Potassium and phosphorus transport and signaling in plants." *Journal of Integrative Plant Biology* 63, no. 1 (2021): 34-52.
4. Ali, Ernest Baba, Ephraim Bonah Agyekum, and Parise Adadi. "Agriculture for sustainable development: A SWOT-AHP assessment of Ghana's planting for food and jobs initiative." *Sustainability* 13, no. 2 (2021): 628.
5. Rehman, Amjad, Tanzila Saba, Muhammad Kashif, Suliman Mohamed Fati, Saeed Ali Bahaj, and Huma Chaudhry. "A revisit of internet of things technologies for monitoring and control strategies in smart agriculture." *Agronomy* 12, no. 1 (2022): 127.
6. Kawaguchi, Hidetoshi, Yuichi Nakatani, and Shogo Okada. "IDPS signature classification with a reject option and the incorporation of expert knowledge." *arXiv preprint arXiv:2207.10797* (2022).
7. Finger, Robert, Scott M. Swinton, Nadja El Benni, and Achim Walter. "Precision farming at the nexus of agricultural production and the environment." *Annual Review of Resource Economics* 11 (2019): 313-335.
8. Saffan, Mohamed M., Mohamed A. Koriem, Ahmed El-Henawy, Shima El-Mahdy, Hassan El-Ramady, Fathy Elbehiry, Alaa El-Dein Omara, Yousry Bayoumi, KhandSUREN Badgar, and József Prokisch. "Sustainable production of tomato plants (*Solanum lycopersicum* L.) under low-quality irrigation water as affected by bio-nanofertilizers of selenium and copper." *Sustainability* 14, no. 6 (2022): 3236.
9. Deines, Jillian M., Kaiyu Guan, Bruno Lopez, Qu Zhou, Cambria S. White, Sheng Wang, and David B. Lobell. "Recent cover crop adoption is associated with small maize and soybean yield losses in the United States." *Global change biology* 29, no. 3 (2023): 794-807.
10. Pavithra, M., R. Rajmohan, T. Ananth Kumar, S. Usharani, and P. Manju Bala. "Investigation of Energy Optimization for Spectrum Sensing in Distributed Cooperative IoT Network Using Deep Learning Techniques." *Hybrid Intelligent Approaches for Smart Energy: Practical Applications* (2022): 107-127.