

Solar Cell Trends and the Future: A Review

A. Garg¹, R. K. Ratnesh^{2*}

^{1,2}Department of Electronics & Communication Engineering, Meerut Institute of Engineering & Technology, Meerut, UP, 250005, India, Affiliated to Dr. A P J Abdul Kalam Technical University, Lucknow, UP, India.

Email: ratnes123@gmail.com

DOI: 10.47750/pnr.2022.13.S06.268

Abstract

In this review paper, we highlight about the generations and types of solar cells. The development in solar cells have seen a rapid advancement in the efficiency and quality of various materials, in the recent years. Moreover, this paper elaborates about the dye-sensitized, perovskites, multi-junction solar cells and also the latest and future of solar cells that is organic and polymer solar cells. The objective of this paper is to introduce the solar cells and analyzing the performance of various solar cells.

Keywords: Photovoltaic effect, Amorphous silicon, Quantum dots, Organic and polymer, Multi-Junction.

I. INTRODUCTION

Solar energy is the leading method among all renewable energy sources and is also capable of replacing the conventional energy sources in coming decades. Generation of electricity from energy source which is eco-friendly, free from pollutants has increased the interest among the researchers for doing research in this direction [1][2]. The emission produce from the fossil fuels is threatening and will deplete the ozone layer in coming days. Solar energy is rich in nature and it is one of the types of renewable energy. This source of energy is free, unlimited, inexhaustible and fastest producing energy [3-5].

Solar cells are based on Photovoltaic technology (PV). In Photovoltaic, “Photo” stands for light and “voltaic” stands for voltage. A PV system converts light energy into electricity directly by photovoltaic effect. In 1839, a scientist named Alexandre-Edmund Becquerel was doing experiment with an electrolyte solution, it was found that the electricity generation increases after exposing to the light. In 1870, the photovoltaic effect was firstly studied in solids i.e. Selenium. The method was less efficient and costly. After which Czochralski method was developed [6]. Solar cells made from various types of materials and one of the leading and commonly used material is Silicon (Si). Silicon is abundant in nature and can be used in various forms such as amorphous, single-crystalline and multi-crystalline. Some of the characteristics of silicon is, they are more efficient and reliable. Due to the high cost of silicon, scientists are searching an alternative material which is having minimal cost to produce solar cell [7-9].

This review, reveals the history, latest advancement, and various generations of solar cell. Furthermore, it includes various factors affecting the efficiency and their remedy. Moreover, a comparative study on efficiency of all generations solar cells also included. Hence, the motive of the manuscript is to show comparison as well as discovering new technologies for the gradually enhancement in solar technology.

II. EVOLUTION OF SOLAR

After the study of photoelectric effect, the evolution of solar cell started which has been very well illustrated in Fig. 1.

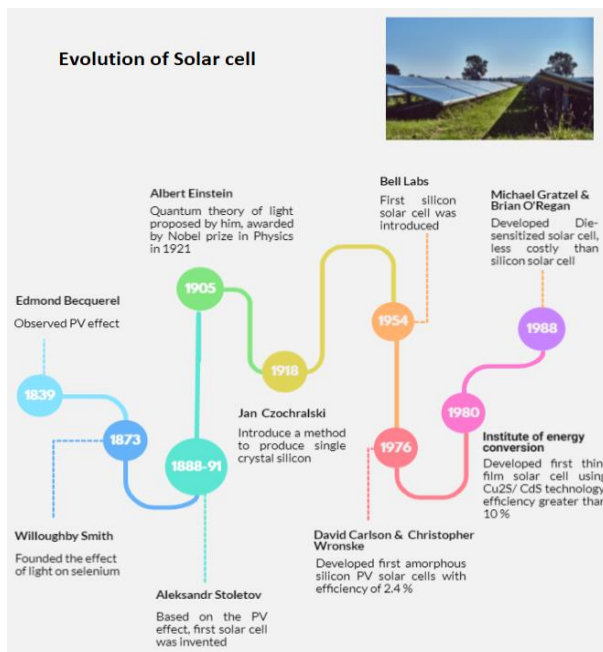

Fig.1 Evolution of solar cell

The work on solar cell began in 1839 after the observation of PV effect by Edmond Becquerel, the physicist. Then the first solar cell was invented based in 1888 based on PV effect by the scientist Aleksandr Stoletov. The Bell Laboratory were first introduced the silicon solar cell in 1954 [10]. After 1954, there was a gradual development in the generations solar cell.

III. GENERATIONS & TYPES OF SOLAR CELL

There are various generations and types of solar cells which are categorized mainly into three generations as shown in Fig. 2. The first-generation solar cell is a wafer technology and it is associated in many mono-crystalline and poly-crystalline wafers. The second-generation solar cells are popularly known as thin-film technology mainly divided into: Amorphous silicon, Cadmium telluride (CdTe), Copper indium gallium di-selenide (CIGS) etc. Likewise, the third-generation solar cells also known as the new emerging technology such as, Die-sensitized solar cells (DSSC), Perovskite solar cells, Organic solar cells, multi-junction solar cells etc. [11].

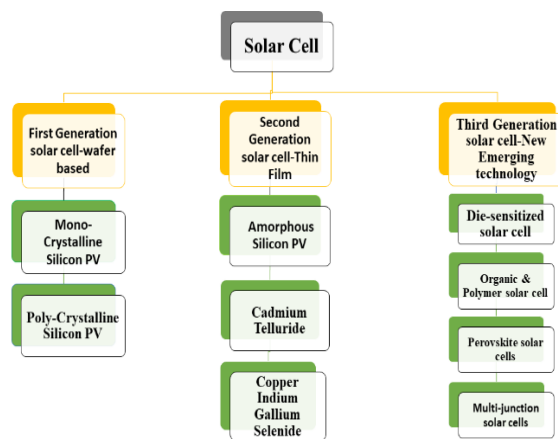

Fig. 2 Development of PV production i.e., Thin-film, Mono-Si, Multi-Si [12]

IV. FIRST GENERATION SOLAR CELL

The first-generation solar cell, fabricated by Bell laboratories in 1953 with efficiency of 4.5% and produced in 1954 with efficiency of 6% [13]. This wafer based solar cells are processed on silicon wafers. This type of solar cells has high power efficiencies. The silicon solar cell is further divided in two parts: first is doped with n-type and second one is doped with p-type [14]. In this the p-n junction is created and the process of diffusion occurs in which the positive charges known as holes and the negative charges that are known as electrons start moving towards their region. Finally, when the metal contacts are created, the power is generated in the circuit, resulting in the formation of circuit [4]. They are further bifurcated into two types are: Mono-crystalline silicon solar cell and Poly-crystalline silicon solar cell. The tabular comparison of first-generation solar cells is shown in table. 1.

Table. 1 Summary of first-generation solar cells [15]

Types of solar cells	Efficiency	Advantages	Disadvantages
Mono-crystalline solar cells	15-24 %	1. Highly efficient than poly-crystalline solar cells. 2. Less space is occupied in mono-crystalline.	1. The manufacturing process is highly complex. 2. It is expensive.
Poly-crystalline solar cells	10-18 %	1. Less expensive than mono-crystalline.	1. Efficiency is less than mono-crystalline solar cells.

V. SECOND GENERATION SOLAR CELL

The thin-film technology is more economical than first generation solar cell. The cost of production is minimized in this generation due to poor quality material that is deposited on cheap substrates [11]. The thin films are stacked in layers. These stacked layers can absorb light of different wavelengths. The concept of stacked layers reduces the mass of the material [14]. The thin layer is made of intrinsic photoactive material between p and n-type [4]. The second generation are again categorized in the following ways and summarized below in table. 2.

A. Amorphous Silicon (a-Si) Solar cell

The meaning of “Amorphous” is having no fixed shape. In this, silicon material has lack of definite arrangement in the atoms. It is not highly structured. The silicon and carbon amorphous alloys known as amorphous silicon carbide denoted as a-SiC and the hydrogenated amorphous silicon carbide is denoted as a-Si_{1-x}C_x:H.

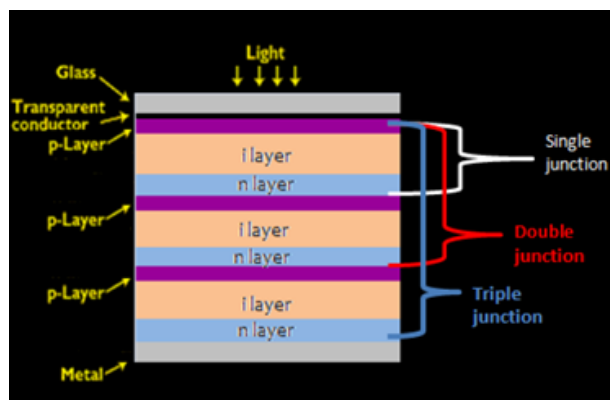

Fig. 3 Structure of amorphous silicon solar cells [16]

The structure of amorphous silicon solar cell is shown in Fig. 3. In the fabrication process of a-Si cell, the back side is coated by the doped silicon material. The a-Si solar cells have the capability of absorbing the light more effectively than conventional silicon solar cells.

B. Cadmium Telluride (CdTe) solar cell

Cadmium telluride photovoltaics solar cell consists of thin film. The thin semiconductor layer is used to convert the light energy into electricity [11][14]. It is one of the thin film technologies that is less costly in comparison from other solar cells that are made up of crystalline silicon [17]. In 2013, the global market share of CdTe solar cell was approx. 5% and that of thin film technology was 56%. The bandgap of CdTe is about 1.5eV. The advantages of CdTe solar cell are that it has high optical absorption coefficient and chemical stability [17]. The structure of CdTe consists of various layers of cadmium sulphide and cadmium telluride, also have the layer of transparent conducting oxide (TCO) as shown in Fig. 4.

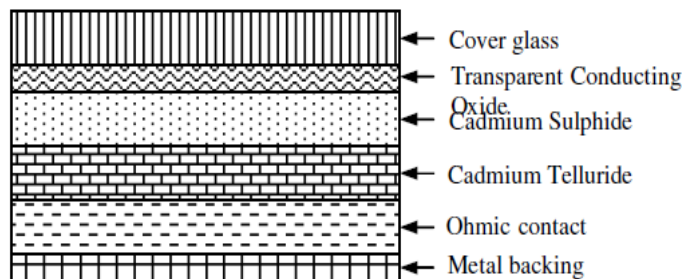

Fig. 4 Structure of CdTe solar cell [17]

One of the techniques of depositing thin films is electro-deposition. In this technique, the thin film of both CdTe and CdS is formed at the temperature at 90° C approx. The aqueous solution consists of CdSO₄ and Te₂O₃. The chemical reaction of formation of CdTe is shown below.



Copper Indium Gallium Di-selenide (CIGS)

The CIGS is highly efficient thin film technology [14]. CIGS comprises of four compounds which are named as: Copper, Indium, Gallium and Selenium. The CIGS is represented in the chemical form of CuIn_(1-x)Ga_(x)Se₂ where x is defined between 0 and 1. The band gap of CIGS differs from 1.0-1.7 eV, depending on what ratio the elements in the compound are mixed [18][19]. There are various techniques like: sputtering, evaporation, electrochemical coating technique, printing and electron beam deposition using which CIGS can be processed. The five-layer structure of CIGS have substrate of glass plate, polymers, steel and aluminum which is shown in Fig. 5 [10].

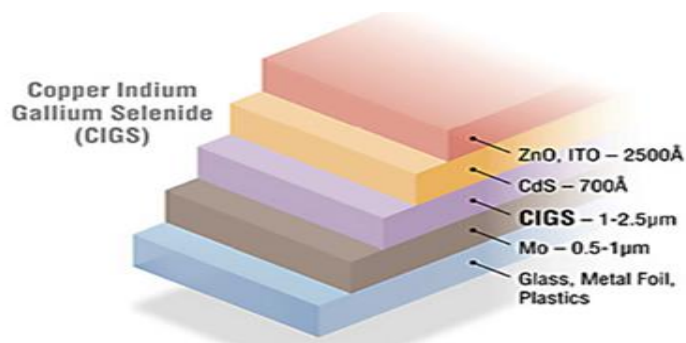

Fig. 5 Shows CIGS solar cell consisting of 5-layers [10]

Table. 2 Summary of second-generation solar cells [15]

Types of solar cells	Efficiency	Advantages	Disadvantages
Amorphous silicon solar cells	5-12 %	<ol style="list-style-type: none"> 1. Light in weight. 2. It is Less expensive than C-Si. 3. It absorbs more energy than C-Si. 	<ol style="list-style-type: none"> 1. Less efficiency than C-Si. 2. The installation time and space required is more.
Cadmium telluride solar cells	15-16 %	<ol style="list-style-type: none"> 1. Performance in high temperature is good. 2. Less expensive than conventional solar cells. 	<ol style="list-style-type: none"> 1. Cadmium is highly toxic. 2. Tellurium is not abundant.
CIGS	20 %	<ol style="list-style-type: none"> 1. Performance in high temperature is good. 2. Less expensive than conventional solar cells. 	<ol style="list-style-type: none"> 1. The structure is highly complex. 2. Stability is low.

VI. THIRD GENERATION COLAR CELL

The Third-Generation solar photovoltaic cells have an ability to generate the electricity. It consists of three families with different principles are as follows: polymer: fullerene, hybrid polymer, perovskites solar cells. It is a new emerging technology that has arisen after the first generation-wafer based and second generation-thin films shown in Fig. 6 and the summary of all types is shown in table. 3 [20]. These types of solar cells are introduced to minimize the drawbacks of the first and second-generation solar cells. The major objectives of third generation solar cell are given below.

- To reduce production cost
- To increase the power conversion efficiency

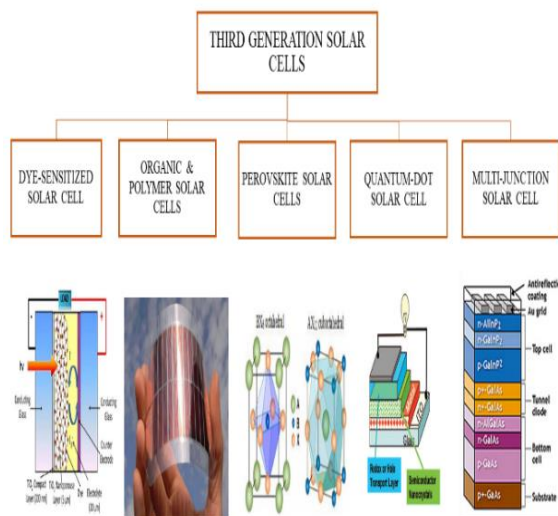

Fig. 6 Classification of third generation solar cells [14] [21]

A. Dye-Sensitized Solar Cell (DSSC)

These are the third-generation photovoltaic solar cell, converts the light into electrical energy [11][22]. It is low-cost thin film solar cell due to the fabrication costs, dyes or low-cost material used in manufacturing of the solar cell [23]. The modern DSSC consists of a layer which is porous in nature. The layer is of Titanium dioxide (TiO_2) nanoparticles and it is covered with molecular dye which is used to absorb sunlight. The working of DSSC has clearly understand on the basis of following schematic representation Fig. 7.

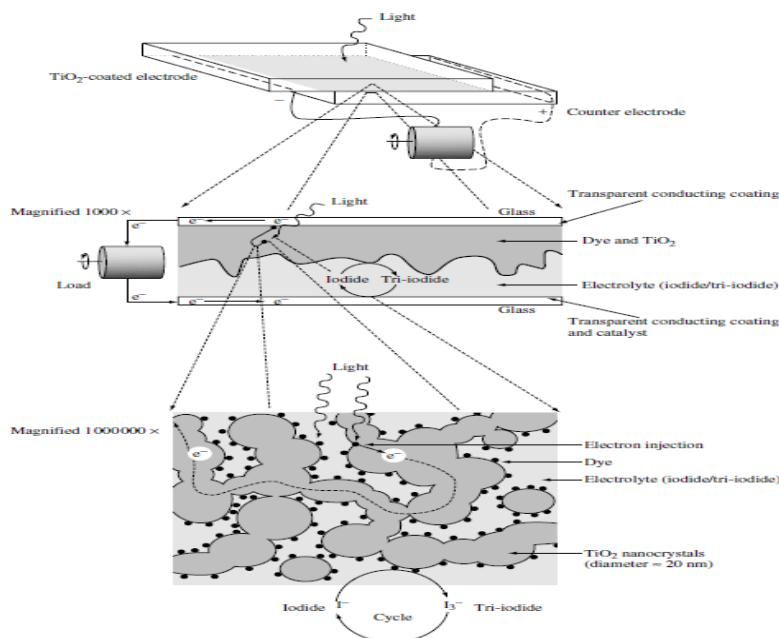
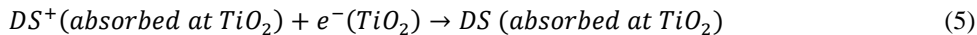
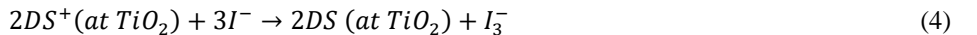
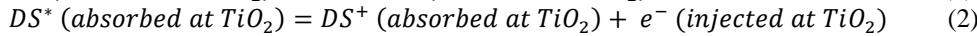
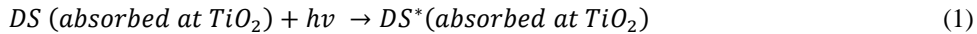

Fig. 7 Structure of Dye-sensitized solar cell [24]

The generation of current is explained with the help of equation (1) to (3). The electron transfer mechanism is shown below in equations (1) to (5).



Some of the features of DSSCs are: semi-flexible in nature, semi-transparent in nature and also uses conventional roll-printing technology.

B. Organic & Polymer Solar Cells

The first organic cell was fabricated by Calvin in 1958. In layman language, organic solar cells made from carbon material i.e., these carbon materials are responsible for photovoltaic action. The category on which these organic solar cells belonged are excitonic solar cells that means bonded electron hole pairs generated after the light is incident or illuminated [25]. The nature of the absorbent material is organic i.e., the structure consists of carbon atom C. As the organic compounds are made up of several carbon atoms, therefore, they are known as organic solar cells. There are some examples of organic materials like: P3H (Poly(3-hexylthiophene-2,5-diyl)), phthalocyanine (contains 32 carbon atoms), PCBM (Phenyl-C61-butyric acid methyl ester) shown in Fig. 8.

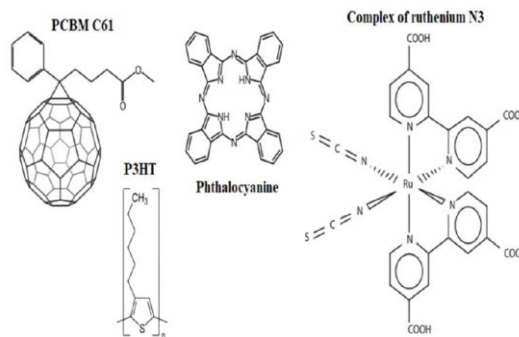

Fig. 8 Examples of organic materials [25]

C. Perovskite Solar Cells

Perovskite solar cells is new technology compare to third generation photovoltaics [26]. These cells are inherited from the properties of dye-sensitized solar cells (DSSC), which are invented in 1990 with high efficiency 25% [4]. The general representation of perovskite is ABX_3 , where A and B are cations and X is anion. In 2009, the efficiency of perovskite solar cells was 3.8%. And now the efficiency has been improved to 22.13% in 2018. Perovskite is a material from broad family which is surrounding of conductors, insulators and superconductors. They have different properties like: thermoelectric, piezoelectric and ferroelectric properties. This material is present in the ample amount on the earth which is present in the form of magnesium silicate i.e., $MgSiO_3$ [4]. There are various advantages of this material in the solar cell like: low recombination losses, cost of material is low as well as charge carrier diffusion length is longer [23].

The structure of the solar cell is shown below in Fig. 9.

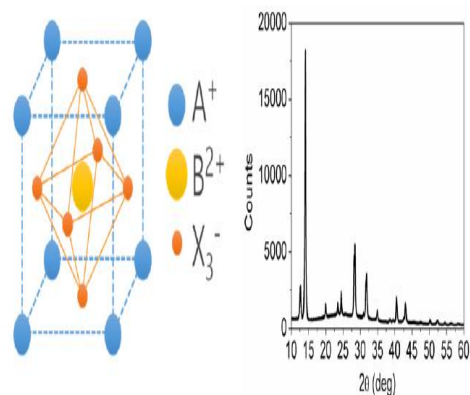

Fig. 9 Structure of perovskite solar cells and XRD spectrum [26]

D. Quantum-dot Solar Cells

The Quantum-dot solar cell is one of the prevalent technologies in the solar industry. The solar cells made of bulk materials like: silicon, copper indium gallium selenide or cadmium telluride (CdTe) have been replaced by quantum-dot solar cells. Originally, the concept of adopting quantum dots technology for higher efficiency was introduced by Burnham and Duggan in 1989 [27]. The band gap of quantum dots is tuneable by changing the size of dots. These are also known as artificial atoms. The bandgap can be varied with respect to the size of dots without changing the material. The difference between the quantum-dot and bulk materials is of bandgap i.e., the bandgap of quantum-dot is variable whereas the bandgap of bulk material is fixed. According to the latest report, the efficiency of quantum-dots solar cell achieved is 18.1% [28].

The architecture of QDSCs shown in Fig. 10 is the further modification of DSCs where an organic dye molecule is replaced as the light harvesting material. The QDSCs consists of: QD sensitized photoanode, counter electrode and an electrolyte.

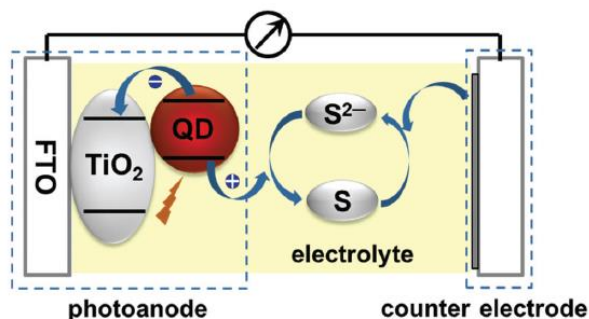

Fig. 10 Architecture of QDSC [28]

E. Multi-junction Solar Cells

The current necessity of multi-junction solar cells or tandem solar cells is to develop the cost effective and highly efficient solar cells [29]. Multi-junction solar cells are made up of several p-n junctions which are sandwiched together and commonly made from different semiconductor materials as shown in Fig. 11.

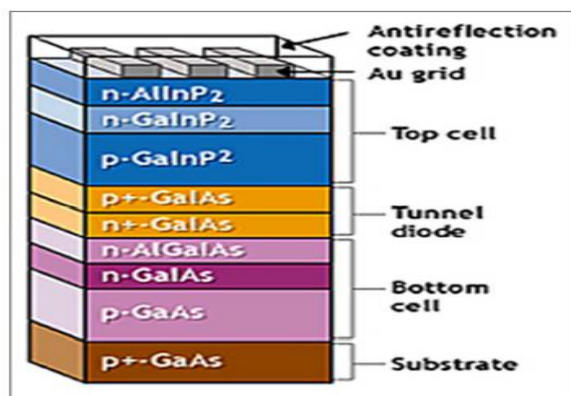

Fig. 11 Multi-junction solar cells [11]

In multiple junction electric current will be produced with respect to different wavelengths of sunlight. Thus, the efficiency to convert the sunlight into electrical energy has been improved. The solar panels that are made up of only single material can convert the light up to 15% into electricity while multijunction solar cell have reported high solar conversion efficiency ~45% [11][29].

Table. 3 Summary of third-generation solar cells

Types of solar cells	Efficiency	Advantages	Disadvantages
Dye-sensitized solar cells	5-20 %	1. Semi-flexible in nature. 2. Low cost thin-film solar cells. 3. Roll to roll production is possible.	1. Stability is low.
Organic/Polymer solar cells	9-11 %	1. Performance in high temperature is not good. 2. Light weight and flexible in nature.	1. Lifetime is less as compare to inorganic solar cells. 2. Efficiency is less.
Perovskite solar cells	21 %	1. Less expensive and easy to process than conventional solar cells. 2. Cost of material is low. 3. Thermal stability is good.	1. Consists lead that is a highly toxic material.
Quantum-dots solar cells	11-17 %	1. More attractive than multi-junction solar cells because of the bandgap properties. 2. Have ability to tune bandgap.	1. Less efficient than conventional solar cells.
Multi-junction solar cells	36 %	1. Highly efficient than conventional silicon solar cells. 2. Less space is required as multiple layers are stacked on one another.	1. Highly expensive.

VII. CONCLUSION

The Solar energy is one of the best renewable energies for the better tomorrow. The review paper is based on the solar cell technology. The various types of solar cells which are elaborated are: conventional, thin-film, organic etc. The paper highlights the efficacy of all the solar cells in a tabular form. As of right now, the various types of solar cell had been invented to enhance

the efficiency. The organic and polymer solar cells are one of the most popular technologies in the industry. With the help of the review paper, we tried to illustrate the difference between the characteristics of generation.

Acknowledgments

Thanks to Department of electronics and communication engineering, Meerut Institute of Engineering and Technology (MIET) for providing useful infrastructure and support to conduct this research.

REFERENCES

1. Y. Chu and P. Meisen, Review and Comparison of Different Solar Energy Technologies, Report of Global Energy Network Institute (GENI), Diego, 2011.
2. P. C. Choubey, A. Oudhia and R. Dewangan, A Review: Solar Cell Current Scenario and Future Trends, Recent Research in Science and Technology, 2012, 4, 99-101.
3. L. Cutz, O. Masera, D. Santana and A. P. C. Faaij, Switching to efficient technologies in traditional biomass intensive countries: the resultant change in emissions, Energy, 2017, 126, 513-526.
4. R. K. Ratnesh and M. S. Mehata, Tunable single and double emission semiconductor nanocrystal quantum dots: A multianalyte sensor, Methods and Applications in Fluorescence, 2018, 6, 035006. doi.org/10.1088/2050-6120/aaba8a
5. R. K. Ratnesh, M. Singh, S. Pathak and V. Dakulagi, Reactive magnetron sputtered-assisted deposition of nanocomposite thin films with tunable magnetic, electrical and interfacial properties, Journal of nanoparticle research, 2020, 22, 290. doi.org/10.1007/s11051-020-05017-z
6. H. M. Ali, S. M. Reda, A. I. Ali and M. A. Mousa, A quick peek at solar cells and a closer insight at perovskite solar cells, Egyptian Journal of Petroleum, 2021, 30, 53-63. doi.org/10.1016/j.ejpe.2021.11.002.
7. V. Raja Sekhar and P. Pradeep, A Review Paper on Advancements in Solar PV Technology, Environmental Impact of PV Cell Manufacturing, International Journal of Advanced Research in Science, Communication and Technology, 2021, 8, 2581-9429. doi.org/10.48175/IJARSCT-1887.
8. O. P. Yadav, A. Varshney, A. Kumar, R. K. Ratnesh, and M. S. Mehata, A2B Corroles: Fluorescence Signaling Systems for Sensing Fluoride Ions, Spectrochimica Acta Part A: Molecular and Biomolecular Spectroscopy, 2018, 202, 207-213. doi.org/10.1016/j.saa.2018.05.051
9. Chandan, R. K. Ratnesh and A. Kumar, A Compact Dual Rectangular Slot Monopole Antenna for WLAN/WiMAX Applications, Innovations in cyber physical systems, LNEE, 2021, 788, 699 - 705. doi.org/10.1007/978-981-16-4149-7_63
10. April 25, 1954: Bell Labs Demonstrates the First Practical Silicon Solar Cell, APS News, American Physical Society, 2009, 18, 4.
11. A. M. Bagher, M. M. Abadi Vahid, M. Mohsen, Types of Solar Cells and Application, American Journal of Optics and Photonics, 2015, 3, 94-113. doi.org/10.11648/j.ajop.20150305.17
12. Photovoltaics Report, Fraunhofer Institute for solar energy systems, 2022.
13. T. Saga, Advances in crystalline silicon solar cell technology for industrial mass production, NPG Asia Mater, 2010, 2, 96-102, doi.org/10.1038/asiamat.2010.82.
14. R. Swami, Solar Cell, International Journal of Scientific and Research Publications, 2012, 2.
15. P. Kaur, V. Pandey and B. Raj, Comparative Study of Efficient Design, Control and Monitoring of Solar Power Using Internet of Things, American Scientific Publishers, 2020, 18, 419-426. doi.org/10.1166/asl.2020.4225.
16. M. I. Kabir, N. M. Zainee and N. Amin, Analysis of high efficiency amorphous silicon single and multijunction solar cells, 1st International Conference on the Development in Renewable Energy Technology, 2009, 1-5. doi.org/10.1109/ICDRET.2009.5454214.
17. R. K. Ratnesh and M. S. Mehata, Tunable single and double emission semiconductor nanocrystal quantum dots: A multianalyte sensor, Methods and Applications in Fluorescence, 2018, 6, 035006. https://dx.doi.org/10.1088/2050-6120/aaba8a
18. S. Sharma, K. K. Jain and A. Sharma, Solar Cells: In Research and Applications-A Review, Materials Sciences and Applications, 2015, 6, 1145-1155, doi.org/10.4236/msa.2015.612113.
19. M. M. Baig, Solar cells and its applications, International Journal of All Research Education and Scientific Methods (IJARESM), 2021, 9, 3493-3500. ISSN: 2455-6211
20. J. Yan and B. R. Saunders, Third-generation solar cells: a review and comparison of polymer: fullerene, hybrid polymer and perovskite solar cells, RSC Adv., 2014, 4, 43286-43314.
21. P. V. Kamat, Quantum Dot Solar Cells-Semiconductor Nanocrystals as Light Harvesters, J. Phys. Chem. C, 2008, 112, 18737-18753.
22. R. K. Ratnesh, Hot injection blended tunable CdS quantum dots for production of blue LED and a selective detection of Cu²⁺ ions in aqueous medium, Journal of Optics and Laser Technology, 2019, 116, 103-111. https://doi.org/10.1016/j.optlastec.2019.03.001
23. M. V. Dambhare, B. Butey and S. V. Moharil, Solar photovoltaic technology: A review of different types of solar cells and its future trends, Journal of Physics: Conference series, 2021, 012053. doi.org/10.1088/1742-6596/1913/1/012053.
24. K. L. Chopra, P. D. Paulson and V. Dutt, Thin-Film Solar Cells: An Overview. Progress in Photovoltaics, 2004, 12, 69-92. doi.org/10.1002/pip.541.
25. V. Helac, H. Samic, S. Hanjalic and B. Nikolic, Influence of organic materials on solar cells efficiency, 17th International Symposium Infotech-Jahorina, IEEE, 2018, 1-5. doi: 10.1109/INFOTEH.2018.8345525.
26. M. De Bastiani, Ph.D. Thesis: The stability of third generation solar cells, 2016.
27. X. Michalet, F. F. Pinaud, L. A. Bentolila, J. M. Tsay, S. Doose, J. J. Li, G. Sundaresan, A. M. Wu, S. S. Gambhir and S. Weiss, Quantum Dots for Live Cells, in Vivo Imaging, and Diagnostics, Science, 2005, 307, 538-44. doi.org/10.1126/science.1104274.
28. Z. Pan, H. Rao, I. Mora-Sero, J. Bisquert and X. Zhong, Quantum dot-sensitized solar cells, Chem. Soc. Rev., 2018, 47, 7659, doi.org/10.1039/c8cs00431e.
29. F. Dimroth et al., 34.1 % Efficient GaInP/AlGaAs/Si Tandem Cell, 47th IEEE Photovoltaic Specialists Conference, 2020, 1543-1546, doi.org/10.1109/PVSC45281.2020.9300698.