

Novel Approach Of Breast Cancer Detection Based On Wireless Communication System

¹Manoj prasath .T , ²M.Hari Hara Suthan , ³Dr Diksha Srivastava , ⁴Rohith P , ⁵Dr. Harpreet Kaur , ⁶Dr. Allam Balaram

¹Bharath institute of Higher Education and Research, Chennai-73

²Bharath institute Higher Education and Research, Chennai -73

³Department of Allied medical science and technology, India

⁴Department of ECE, Rajeev Institute of Technology, Hassan

⁵Lovely Professional University, Punjab Phagwara

⁶Department of Information Technology, MLR Institute of Technology, Hyderabad, India

¹mprasath.t@gmail.com, ²hari.biomedical@gmail.com, ³diksha.shrivastva@nimsuniversity.org,

⁴rohithgowda1985@gmail.com, ⁵harpreet.27633@lpu.co.in, ⁶drbalaramallam@gmail.com

Corresponding Author: ¹mprasath.t@gmail.com

DOI: 10.47750/pnr.2023.14.S02.119

Abstract

Breast cancer is one of the leading causes of death for women worldwide. It is a multilevel disease characterised by aberrant breast tissue development. As a patient's stage progresses, his or her odds of being treated and of surviving decreases. As a result, it is critical to identify and treat breast cancer early. Microwave imaging for breast cancer detection is an intriguing technology for detecting tumours, and it has a lot of benefits over other breast cancer detection methods that are already in use. UWB technology is mainly widely prescribed for usage in such an applications because to its special qualities such as short-range, non-ionizing, and broad bandwidth have used a UWB antenna sensor network to image and detect breast cancer. Non-ionizing radio waves are one of them. Its benefits are adaptability, a low-cost technology, and human body safety. For receiving and sending microwaves, microwave vision relies on a microstrip patch antenna. As the term suggests, a micro strip patch antenna is a small, light antenna. Microstrip patch antennas are classified as flexibility or non-flexible dependent on the substrate surface. They designed a simple recursive antenna (peano patch antenna) for the Ultra-Wideband frequency (6.744 GHz) (-42.657 dB). The antenna options for breast imaging on a transmitter is an antenna array composed of 18 antennas. The antenna is designed in a circular shape to allow it to face exactly at the image of the breast for greater disease diagnosis.

Keyword: Microwave imaging, breast cancer, wearable antenna, ultra-wideband frequency

I . INTRODUCTION:

Cancer is the biggest cause of mortality globally, according to the World Health Organization; account for more than half of deaths (WHO). Cancer is a broad term that refers to a variety of disorders marked by the multistage development of abnormal cells beyond their normal limits. Such individuals can then spread to other regions of the body, affecting the entire tissue.

The most common cancers are lung cancer, breast cancer, prostate cancer, skin cancer, stomach cancer, and other cancers. Frequent [1]. A tumour can be classified as either normal or abnormal. Tumours that are normal are not malignant. Malignant tumours are malignant tumours that can spread to other regions of the body. When cancer has progressed to every region of the body or to other parts, it has become challenging to save another patient's life. As a result, early detection is essential for the patient's life. Wearable technology has already been utilised to track a variety of human bodily characteristics [2]. Wearable antennas, which are an important component of WBAN systems, can be used to transmit and receive impulses to the human body, such as a can detect the presence of a tumour in a pair of breast. The impacts of high loss and high permittivity tissues, as well as the effects of high loss and high transmittance connective tissue, present a number of obstacles when building antennas in the presence of the human body [3]. All wearable antennas collaborate contact to the human body's high dielectric

medium or connect with the human body in a way that impacts the development's radiation patterns. The Q factor of the wearable device is affected as relative permittivity grows parts of a human body, and electric flow is inhibited [4]. As a result, when the antenna comes into contact with the body, its performance decreases. As a result, antennas must still be carefully built to sustain effectiveness when they come into contact with a substance other than empty space [5].

II . RELATED WORK:

The efficiency of thin strip antennas, wearable antennas for medical applications, and antennas specialised for breast cancer diagnostics will all be investigated. [6] Micro strip antennas are a crucial technological advancement that is used in a variety of medical applications, including medical implants, wireless monitoring, microwave imaging, and other on-body applications.[7] The Ultra-Wide Band (UWB) approach provides a plan to accomplish this primary goal. In accordance with U.S.A standards, UWB's medical diagnosis and observation equipment was typically kept in within uncontrolled 3.1 GHz to 10.6 GHz and 3.4 GHz to 8.5 GHz are the frequency ranges. Non-ionizing radiation, UWB signals are especially effective at reaching human body structure.[8]As a result of the non-destructive modelling of human organs, this method is particularly valuable in biomedical applications. In the real production phase of UWB medical equipment, antennas were used as essential contain many types of every wireless contact device.[9] The usage of antenna in biomedical applications, specifically for cancer diagnosis, has grown rapidly in recent years.

The use of UWB technologies in wide variety of biomedical applications is very exciting and is often seen as the well-known UWB microwave imaging medical imaging method.[11] The method is often quite enticing to use for the development of the peripheral diagnosis of breast cancer. It's almost certain that the highlighted the critical of the medical recognition and tracing concept will be really simple; antenna, RF, and DC circuits will be low; and the prototype will be simply accessible and inexpensive. [15] High resolution artefacts can be recovered using UWB pre-processing with a wide bandwidth (> 500 MHz). [16]

III . PROPOSED METHOD:

Trigger output

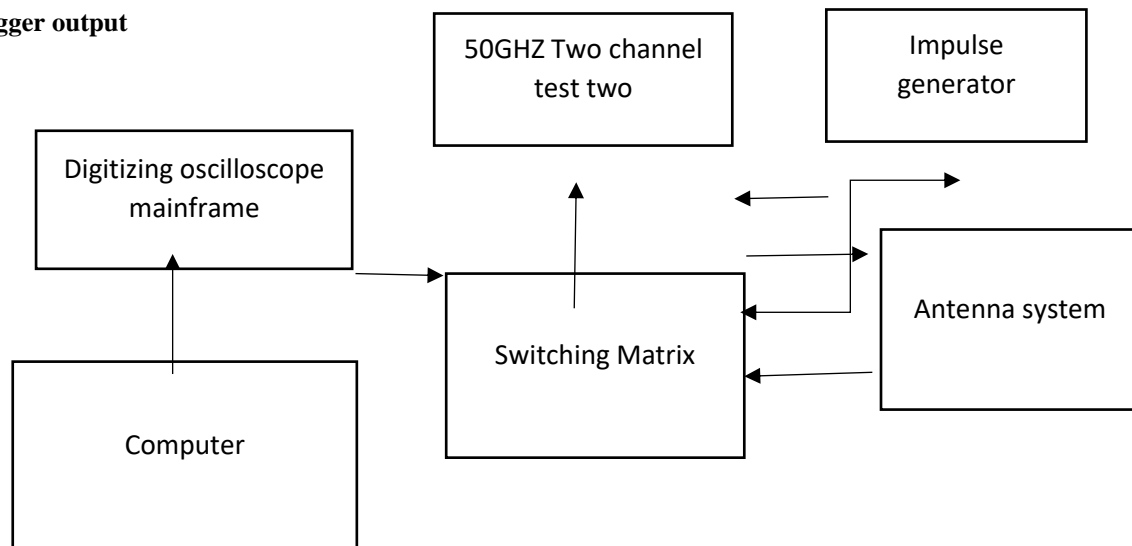

Fig.1:The ultra-wideband time domain microwave is depicted as a block diagram.

Figure 1 depicts the block diagram of the UWB transfer function microwave imaging system. An instantaneous conversion, a measurement device, an antenna array, and a changeable array make up the basic experimental apparatus. The samples oscilloscope is made up of a platform and a two-channel bandwidth testing dataset. One of the transmitters transmits the initiative signal created by the impulse generator into the object-under-test, and the

dispersing region is collected by the later antenna design. The sampling scope then samples and digitises the obtained signals. This operation is continued until all of the antennas have been used to send data. To find different sender and receiver antenna pairs, the changing sequence is employed. The activate output of the impulse generating is already connected to the trigger input of the two-channel test set, resulting in synchronisation between both the transmitter and receiver components. Due to the general personal computer, the entire system is computerized. The transmitter antenna emits information in the planned antenna system, after which the image of the breast phantom is illuminated and the reflected radiation as from models of the breast phantom are collected by the received signals. The back-scatter signal helps in the creation of the UWB breast cancer image.

3.1 Antenna design for a micro strip rectangular patch:

Microstrip patch antennas are constructed from patches of electrical conductors on a substrate material above the ground plane and supplied by a Microstrip or coplanar transmission system. This antenna is often referred to as an integrated antenna since it is frequently utilised with microwave electronic components. A Micro strip Patch antenna is made up of an antenna structure on one side of a dielectric substrate material with a ground plane and from the other.

3.2 Patch Antennas with Micro Strips for Biomedical Applications:

Micro strip patch antennas are a significant inventions innovation that can be found in a range of clinical applications like as implant materials, wireless monitoring, electromagnetic imaging, and a variety of other on-body different applications. In this field, a study of the Multiple Ring Slot Ultra-Wideband (MRS-UWB) patch antenna for biomedical field was published recently. The suggested ring slot antenna was designed on a FR-4 base and operated via a micro strip line by simultaneously balancing the feed's thickness and placement, as well as the width of the overall ground. In the feed line, rectangular slits were employed as stairwells, and the ground plane was truncated at the corners. The proposed antenna delivers impressive results of UWB design extending from 2-12 GHz based on 10dB bandwidth requirement.

3.3 Breast Cancer Tumor Detection with a UWB Antenna:

Researching ultra-wideband technology and constructing the suggested antennas for tumour detection took a lot of time and effort. The UWB imagining sensor can recognize little or large tumours based on a frequency sweep. The outcomes of an ultra-wideband breast cancer detection methods incorporating a wideband oscillator, a pulse generator, and a variety of tiny UWB antennas in an assembly arrangement. The key advantage of this technology is that it has been shown in experiments to be possible to detect early breast cancer using a time domain processing ultra-wideband system. In order to achieve a tiny antenna of suitable size for the array arrangement, a few antennas are being researched and developed.

IV. RESULT ANALYSIS:

Microwave radiation is partially transparent to the breast for imaging. With regular and malignant tissues, there may be a considerable electromagnetic characteristic differential.

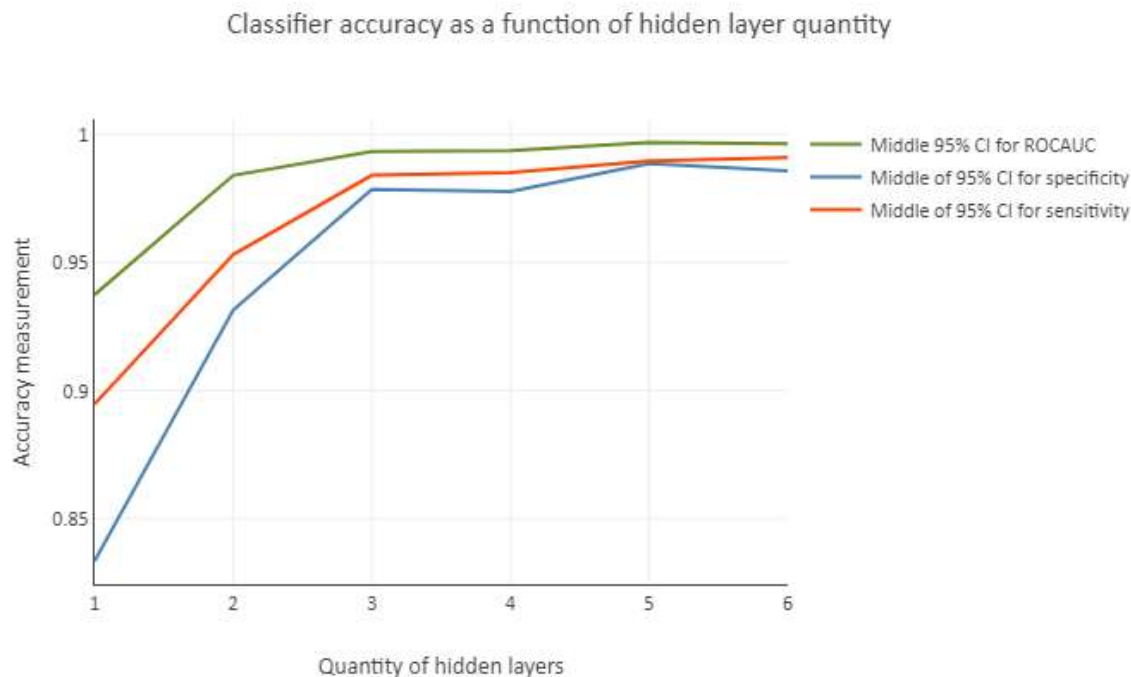

Fig 2: Tumour Breast cancer prediction

Modality	Sensitivity (%)	Specificity(%)	Predictive Value (%)	Accuracy (%)
Mammography	67.85 (120/177)	75.0 (61/81)	85.75 (120/140)	70.20 (181/258)
Clinical examination	50.30 (89/177)	92.0 (75/81)	94.0 (89/95)	63.65 (164/258)
Ultrasound	83.0 (147/177)	34.0 (28/81)	73.50 (147/200)	67.80 (175/258)
Clinical examination & Mammography	77.45 (137/177)	72.0 (58/81)	58.65 (137/160)	75.60 (195/258)
Mammography & ultrasound	91.50 (162/177)	23.0 (19/81)	72.30 (162/224)	70.20 (181/258)
Mammography, clinical examination and ultrasound	93.25 (165/177)	22.0 (18/81)	72.45 (165/228)	70.9 (183/258)
MRI	94.50 (167/177)	26.0 (21/81)	73.60 (167/227)	72.95 (188/258)
Mammography, clinical examination, MRI	99.4%(176/177)	7% (6/81)	70.1% (176/251)	70.5% (182/258)

Table 1: Diagnostic Performance of Different Breast Tumour Detection Technique

The number of relevant diagnosis procedures is limited, as seen in the table. Utilizing mammography, magnetic resonance imaging (MRI), and some therapeutic techniques yielded the maximum sensitivity, 94.4 percent. The greatest efficiency was 75.6 percent, indicating that only one in four diagnostics is incorrect. As a supplement to the already used technology, an accurate, low-cost, non-ionizing, portable, and pleasant solution is desperately needed.

$$\text{Width}(W) = c \cdot 2f_0 \sqrt{\epsilon r + 1} \quad (1)$$

$$\text{eff} = x = \frac{\epsilon r + 1}{2} + \epsilon r x = \frac{\epsilon r + 2}{2} - 1 \sqrt{1 + 12 hW} \quad (2)$$

$$L_{\text{eff}} = c / 2f_0 \sqrt{\epsilon \text{eff}} \quad (3)$$

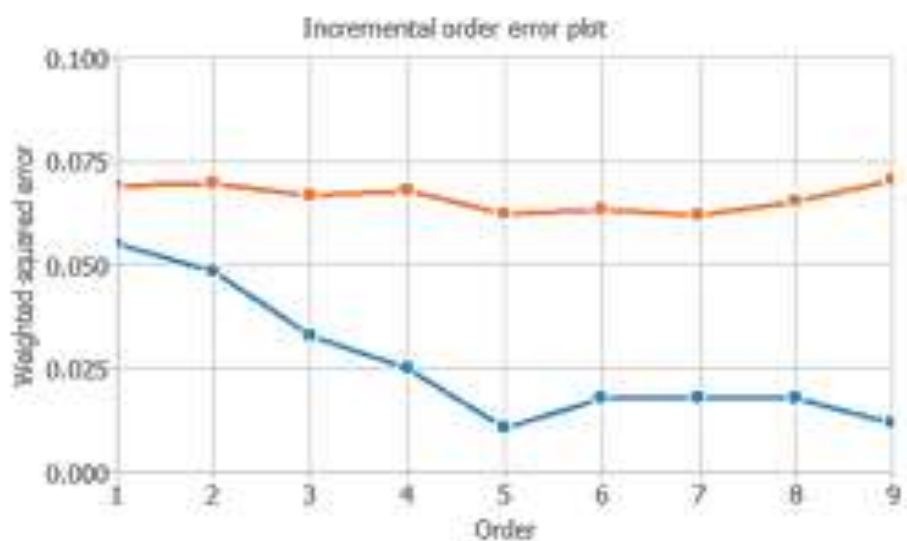

Fig 3: Breast cancer diagnosis using UWB

Microwave-frequency characteristics of tissue have been widely explored and diagnostic applications. The thermal or electrostatic characteristics of a materials in fig 3. Above 15 GHz, the upper band is well realised and falls inside the functional .The lower area below the frequency range, on the other hand, has yet to be accessed.

V. CONCLUSION:

Microwave imaging has been demonstrated to be a feasible option breast screening methods. Microwave stimulation to the human body is completely safe. When compared to other breast screening approaches, microwave image is a simpler and less expensive way to identify a tumour. Moreover, for breast cancer diagnosis and other on-body technologies, microstrip patch antennas, portable and non-portable antennas were investigated. According with studies analysed, tumours up to 3mm in size have now been discovered thus far, but only by compromising on other criteria including such as antenna size, frequency range, and length among antenna and human breast.

REFERENCES:

- [1] K. D. Paulsen and P. M. Meaney, "Nonactive antenna compensation for fixed-array microwave imaging—Part I: model development," *IEEE Transactions on Medical Imaging*, vol. 18, no. 6, pp. 496–507, 1999.
- [2] Q. Fang, *Computational methods for microwave medical imaging* [Ph.D. thesis], Thayer School of Engineering, Dartmouth College, Hanover, NH, USA, 2004.
- [3] E. C. Fear, S. C. Hagness, P. M. Meaney, M. Okoniewski, and M. A. Stuchly, "Enhancing breast tumor detection with near-field imaging," *IEEE Microwave Magazine*, vol. 3, no. 1, pp. 48–56, 2002.
- [4] E. J. Bond, X. Li, S. C. Hagness, and B. D. Van Veen, "Microwave imaging via space-time beamforming for early detection of breast cancer," *IEEE Transactions on Antennas and Propagation*, vol. 51, no. 8, pp. 1690–1705, 2003.
- [5] C. Saunders, L. Wylie, Vineeta Singh and Anita Bourke "New diagnostic techniques for breast cancer detection," *FUTURE ONCOLOGY*, vol. 4, no.4, pp. 501–513, 2008.
- [6] P. Jaglan, R. Dass, and M. Duhan, "Breast Cancer Detection Techniques: Issues and Challenges," *J. Inst. Eng. Ser. B*, vol. 100, no. 4, pp. 379–386, 2019. 3. K. Ouerghi, A. Smida, R. G. And, and N. Boulejfien, "Design and analysis of a microstrip antenna array for biomedical applications," *3rd Int. Conf. Adv. Technol. signal image Process.*, pp. 3–7, 2017.
- [7] H. Zhang, T. Arslan, and B. Flynn, "A single antenna based microwave system for breast cancer detection: Experimental results," *2013 Loughbrgh. Antennas Propag. Conf. LAPC 2013*, no. November, pp. 477–481, 2013.

- [8]. K. Nahalingam and S. Sharma, "An investigation on microwave breast cancer detection by ultra widebandwidth (UWB) microstrip slot antennas," 2011 IEEE International Symposium on Antennas and Propagation (APSURSI), Spokane, WA, 2011, pp. 3385–3388.
- [9]. RabiaÇalışkan, S. S. Gültekin, D. Uzer, and Ö. Dündar, "A Microstrip Patch Antenna Design for Breast Cancer Detection," *Procedia-Social and Behavioral Sciences*, vol. 195, pp. 2905–2911, 2015.
- [10] S. C. Hagness, E. J. Bond, X. Li and B. D. Van Veen, "Microwave imaging via space-time beam forming for early detection of breast cancer," *IEEE Trans. Antenna propag.*, vol. 51, no.8, pp. 1690-1705, August 2003.
- [11] Q. H. Liu, et al., "Active microwave imaging. I. 2-D forward and inverse scattering methods," *IEEE Trans. Microwave Theory and Techniques*, vol. 50, no.1, pp. 123-133, Jan. 2002.
- [12] Y. Wang, A. A. Bakar, M. E. Bialkowski, "Compact Tapered Slot Antennas for UWB Microwave Imaging Applications" *IEEE Microwave Radar and Wireless Communications (MIKON)*, pp. 1-4, August 2010.
- [13] X. Zeng, "Ultra wideband time domain system for microwave tomography", Licentiate thesis, Department of Signals and Systems, University of Chalmers and Technology, Gothenburg, Sweden, 2010.
- [14] R. Nilavalan, I. J. Craddock, A. Preece, J. Leendertz and R. Benjamin "Wideband Microstrip Patch Antenna Design for Breast Cancer Tumour Detection" Department of Medical Physics, University of Bristol, UK, April 2007.
- [15] I. J. Craddock, J. A. Leendertz, A. Preece, D. Gibbins, M. Klemm, and R. Benjamin, "A comparison of a wide-slot and a stacked patch antenna for the purpose of breast cancer detection," *IEEE Trans. on Antennas and Propagation*, vol. 58, no. 3, pp. 665-674, 2010.
- [16] M. Persson, H. Zirath, X. Zeng, A. Fhager, P. Linner, "Accuracy Investigation of an Ultra-Wideband Time Domain Microwave Imaging System", Department of Signals and Systems, Chalmers University of Technology, Gothenburg, Sweden, 2011